



ATR600

P/N 600-(0XX)-(0XX)

P/N 600-(1XX)-(1XX)

VHF Communication Transceiver



Installation and Operation

Dokument-Nr.: 03.1301.010.71e

Revision: 1.03

Date: 04.06.2007

Filser Electronic GmbH • Gewerbestraße 2 • 86875 Waal

phone: 08246 / 96 99-0 • fax: 08246 / 10 49 • web: www.filser.de

CONTENTS

1	GENERAL.....	5
1.1	Symbols.....	5
1.2	Customer Support.....	5
1.3	Survey of Variants.....	5
1.4	Introduction.....	6
1.5	Features.....	6
1.6	Telecommunication Data.....	6
1.7	Technical Data.....	7
1.8	Environmental Conditions.....	9
1.9	Scope of Delivery.....	10
1.10	Accessories.....	10
2	INSTALLATION.....	12
2.1	Unpacking.....	12
2.2	Requirements.....	12
2.3	Antenna.....	13
2.4	On-Board Wiring.....	13
2.4.1	Annotations.....	13
2.4.2	Microphone Connection.....	14
2.4.3	Headphone Connection.....	14
2.4.4	Display Illumination.....	15
2.4.5	Wiring Single-Seater (BSKS600B).....	15
2.4.6	Wiring Double-Seater with Intercom (BSKS600S/T).....	16
2.5	Microphone Settings.....	17
2.5.1	Basics.....	17
2.6	Checkup after Installation.....	18
3	DRAWINGS.....	19
4	OPERATION.....	20
4.1	ON/OFF.....	20
4.2	INIT-Menu – Basic Settings.....	20
4.3	VOL, SQ, VOX, DIM.....	21
4.3.1	Setting Mode.....	21
4.3.2	VOL – Volume.....	21
4.3.3	Squelch.....	21
4.3.4	VOX – Intercom Threshold.....	22
4.3.5	DIM – Background Illumination.....	22
4.4	Transmit Function.....	22
4.5	Frequency Setting.....	23
4.5.1	General.....	23
4.5.2	Direct Input.....	23
4.5.3	MEM – Select from USER-List.....	23



4.5.4	DATA – Select from Frequency Database	24
4.6	Database Download.....	25
4.7	Status and Error Messages.....	25
5	REMOTE CONTROL	26
6	CONTROLS/DISPLAY	27

1 GENERAL

1.1 Symbols

	<p>Instructions whose non-observance can cause damage to the device or other parts of the equipment.</p>
---	--

	<p>Supplementary information.</p>
---	-----------------------------------

1.2 Customer Support

For fastest handling of reshipments please use the reshipment form available from our homepage www.filsers.de.

	<p>Any suggestions for improvement of our manuals are welcome. Feel free to contact service@filsers.de.</p>
---	---

1.3 Survey of Variants

Part Number	Description
P/N 600-(0XX)-(0XX)	Display illumination auto-adjusted with a photoresistor
P/N 600-(1XX)-(1XX)	Display illumination adjusted manually Emergency frequency key (121.50 MHz)

1.4 Introduction

This manual contains information about the physical, mechanical and electrical characteristics and about installation and operation of the VHF Transceiver ATR600.

1.5 Features

- VHF communication transceiver for aircraft installation
- operating range: 118.000 .. 136.975 MHz
- channel spacing: 25 kHz (760 channels)
- mounting: 57-mm cut-out
- 100 user defined frequencies which can be named by 8 characters
- frequency database containing up to 5896 entries
frequency selection by airport names
update via serial interface
frequencies of European airports installed ex factory

1.6 Telecommunication Data

Depending on your national telecommunications legislation, the following data may be required when applying for the aircraft radio station license:

Manufacturer	Filser Electronic GmbH
Type Designation	ATR600
EASA Number	LBA.O.10.911/106JTSO
Transmitter Power Output	6 W
Frequency	118.000 – 136.975 MHz
Emission Designator	6k00A3E

1.7 Technical Data

COMPLIANCE	JTSO-2C37e, ED-23B Class 4 JTSO-2C38e, ED-23B Class C TSO-C37d, RTCA DO-186A Class 4 TSO-C38d, RTCA DO-186A Class C LBA.O.10.911/106 JTSO
APPLICABLE REQUIREMENTS	EUROCAE ED-23B RTCA DO-160D RTCA DO-178B Software Level D
DIMENSIONS	height: 65 mm (2.56 in) width: 65 mm (2.56 in) depth: 248 mm (9.76 in) behind panel (connectors plugged)
WEIGHT	0.6 kg (1.32 lbs)
MOUNTING	panel mounting, cut-out Ø 57 mm
TEMPERATURE RANGES	Operation Storage
	-20 °C to +55 °C; for 30 minutes +70 °C -55 °C to +85 °C
MAX. OPERATING ALTITUDE	50000 ft
VIBRATION	DO-160D, Cat. S, Vibration Curve M
HUMIDITY	RTCA DO-160D, Cat. A
SHOCK	6 G operation 25 G crash safety
RTCA DO-160D ENV. CAT.	[C1Z]CAA[SM]XXXXXXZBAAA[YY]M[B3F3]XXA
POWER SUPPLY	13.8 VDC (11 VDC .. 20 VDC) <ul style="list-style-type: none"> transmitter: 2.5 A (typ.) receiver: 0.1 A (Stand-by without display-illumination), max. 0.5 A emergency operation: 9 VDC
Power Consumption	35 W
FREQUENCY RANGE	118.000 .. 136.975 MHz
FREQUENCY ACCURACY	±30 ppm
FUSE	external fuse required: 3 A, slow-blow
COMPASS-SAFE DISTANCE	30 cm

TRANSMITTER	
POWER OUTPUT	6 W (nominal) 4 W (minimal)
HARMONIC DISTORTION	< 10 % at 70 % modulation
SIDETONE OUTPUT	100 mW into 300 Ω (headphone)
MICROPHONE	standard microphone (Elektret, 50 mV .. 2 V), 100 mVRMS connectable to MIC 1 or MIC 2 or dynamic microphone (MIC 1 switchable)
HARMONIC CONTENT	> 60 dBc
MODULATION FIDELITY	deviation < 6 dB (350 .. 2500 Hz)
CARRIER NOISE LEVEL	> 35 dB at 70 % modulation
UNWANTED FREQUENCY MODULATION	< 3 kHz at m = 70 %/1 kHz
DUTY CYCLE	1 minute on, 4 minutes off; auto turn-off after 2 minutes of continuous transmit operation
RECEIVER	
SENSITIVITY	2.5 μV EMF (6 dB S+N/N, m = 30 % /1 kHz)
BANDWIDTH	-6-dB > ±8.0 kHz
SELECTIVITY	-40-dB < ±17.0 kHz -60-dB < ±25.0 kHz
NF OUTPUT	≥4 W into 4 Ω (speaker output)
AGC CHARACTERISTICS	AF-output variation < 3 dB from 10 μV to 10 mV
AUDIO FREQUENCY RESPONSE	< 6 dB (350 .. 2500 Hz) > 18 dB at 4000 Hz
SQUELCH	auto (manually adjustable)
SPURIOUS RESPONSES AND CROSS-MODULATION PRODUCTS	> 80 dB
DISTORTION (350 .. 2500 Hz)	< 25 % at rated power (85 %/-33dBm) < 15 % at 10 dB below rated power (30 %/-33 dBm)
INTERCOM INPUT	The microphone is connected to the intercom input. 100 mVRMS at the microphone input produce 100 mW output power at the headphone output.

1.8 Environmental Conditions

Characteristic DO-160D	Section	Cat.	Condition
Temperature / Altitude	4.0	C1	
Low ground survival temperature	4.5.1		- 55°C
Low operating temperature	4.5.1		- 20°C
High ground survival Temperature	4.5.2		+ 85°C
High Short-time Operating Temperature	4.5.2		+ 70°C
High Operating Temperature	4.5.3		+ 55°C
In-Flight Loss of Cooling	4.5.4	Z	No auxiliary cooling required
Altitude	4.6.1	C1	50,000 ft
Temperature Variation	5.0	C	2°C change rate minimum per minute
Humidity	6.0	A	
Shock	7.0	A	6 G operational shocks 20 G Crash Safety Test Type R in all 6 directions
Vibration	8.0	S	Vibration Curve M
Explosion Proofness	9.0	X	No test required
Water Proofness	10.0	X	No test required
Fluids Susceptibilities	11.0	X	No test required
Sand and Dust	12.0	X	No test required
Fungus Resistance	13.0	X	No test required
Salt Spray	14.0	X	No test required
Magnetic Effect	15.0	Z	Less than 0.3 m
Power Input (DC)	16.0	B	
Voltage Spike Conducted	17.0	A	
Audio Frequency Conducted Susceptibility	18.0	A	
Induced Signal Susceptibility	19.0	A	
Radio Frequency Susceptibility	20.0	YY	
Emission of RF Energy	21.0	M	
Lightning Induced Transient Susceptibility	22.0	B3F3	
Lightning Direct Effects	23.0	X	No test required
Icing	24.0	X	No test required
Electrostatic Discharge (ESD)	25.0	A	

1.9 Scope of Delivery

Order No.	Description
P/N 600-(0XX)-(0XX) or P/N 600-(100)-(100)	ATR600
SSATR568	connector (Only included, if no cable loom has been ordered)
03.1301.010.71e	manual ATR600 "Installation and Operation"
	EASA Form 1
MA8K1101 (4 pcs)	through-hole screws for panels up to 3 mm

1.10 Accessories

Accessories ATR600

Order No.	Description
BSKS600B	ATR600 cable loom with free ends for gliders
BSKS600E	ATR600 cable loom for airplanes consisting of BSKS600F and BSKSZUB
BSKS600F	ATR600 cable loom with free ends for airplanes without connector set
BSKSZUB	connector set
BSKS600S	cable loom for ATR600 for airplanes incl. 1 x PTT
BSKS600T	cable loom for ATR600 for airplanes incl. 2 x PTT
ZSHM10	swan neck microphone
HSSL40	headset SL-40 classic
HSSL40OP	replacement ear pads for Headset SL-40
MA6K1102 (4 pcs required)	through-hole screws for panels from 3 mm up to 5 mm

Remote Control

Order No.	Description
ZATR600RT	remote control incl. cables and EASA Form 1
BSKS60RT	complete cable loom consisting of BSKS600R1 and BSKS600R2
BSKS600R1	cable loom for remote control (power supply)
BSKS600R2	cable loom for remote control (data cable)

Antennas for Planes

Order No.	Description
SP100	folded-top antenna incl. cable
SP2000	cable folded-top antenna BNC-SS, 0.47 m

Ground Station

Order No.	Description
GS6	ground station incl. battery, antenna and mike
AL2000	charger
32023100	antenna
ZDHMGS6	dynamic hand-microphone with coiled cord and 5-pole plug / 200 Ohm
PNEGAK01	replacement battery 12V/6.5Ah for GS6/GS7

2 INSTALLATION

2.1 Unpacking

- Carefully unpack the equipment.
- Damages due to transport must be reported to the shipping company.
- Save the shipping container and all packing materials to substantiate your claim.



For storage or reshipment the original packaging should be used.

2.2 Requirements

- The installation of the ATR600 depends on the conditions in the airplane. In arrangement with an aeronautical-engineering enterprise, location and kind of the installation are specified.
- Leave sufficient area for the installation of cables and connecting plugs.
- Avoid sharp bends and routing of cables close to control cables.
- Avoid installation close to heat sources.
- Care for adequate convection cooling.
- Remove rotary knobs before mounting:
 - Lift off faceplate with an appropriate tool.
 - Loosen screw and remove rotary knob.
 - Insert cap correctly orientated!
- The equipment is fixed front-laterally with four 6-mm through-hole screws in a 57 mm cut-out.



For assembly in panels of a thickness of 3 mm up to 5 mm, longer screws are needed. Order No. MA6K1102
External fuse required: (3 A, slow-blow)



Note 2.4.2 Microphone Connection BEFORE mounting!

2.3 Antenna

For the ATR600 a conventional vertically polarized VHF COM antenna with a 50 Ohm impedance is needed. Wideband comm antennas provide efficient operation over the comm band. Antennas should be installed in accordance with the manufacturer recommendations.

Installation recommendations:

- consider the manufacturer's recommendations
- Assemble the antenna in vertical position so on or under the belly that it is as far distant as possible from all protruding parts (propeller, chassis, vertical stabilizer).
- To avoid a mutual interference of the radios, the antenna isolation between a voice transmission and a navigation antenna as well as between double COM antennas should be as large as possible. A distance of 2 meters usually is sufficient.
- The metallic contact between airplane surface and antenna must be very good. On non-metallic airplanes a metal foil (min. 80 cm x 80 cm) shall be used as electrical counterweight on the inside of the belly.
- For glider installation the internal antenna installed by the manufacturer should be used.

2.4 On-Board Wiring

2.4.1 Annotations

- The cables must be approved for airplane installation.
- Refer to 1.10 Accessories for cable looms.
- Keep wiring as short as possible.
- Avoid cable running near strong high frequency sources such as ignition coil, generator or battery charger.
- conductor cross-section:
 - power, GND: AWG18 (0.96 mm²)
 - signals: AWG22 (0.38 mm²)
- external slow-blow fuse (3 A) required.

2.4.2 Microphone Connection

Microphone inputs:

MIC 1: for dynamic (factory setting) or standard microphones;
switchable with “Mic Switch“ on the right side of the equipment

MIC 2: (only) for standard microphones; adjustable microphone level

The input for standard microphones is appropriate for input voltages of 50 mVpp to 2 Vpp. This input has a bias voltage of 9 V at 330 ohms. Sensitivity is adjustable in the init menu with MIC.

The input for dynamic microphones is appropriate for input voltages of 5 mVpp to 10 mVpp. This input has no bias.

Microphones of same type should be used, since the adjustments are always concerning both microphone inputs.



Check setting of the MIC switch on the right side of the radio BEFORE mounting!

(Factory setting: dynamic microphone)

Two microphones may be connected parallel per microphone input.

2.4.3 Headphone Connection

Headphones may be connected parallel as long as the total impedance does not fall below 8 Ω .

2.4.4 Display Illumination

Equipment depending differences for connecting LIGHT (Pin 4, brown cable)

P/N 600-(0XX)-(0XX)

- not connected: illumination auto-adjusted
- connected to GND: illumination off

P/N 600-(1XX)-(1XX)

- LIGHT is not connected from the plug into the equipment.
- illumination adjustable with DIM (refer to 4.3.5).

2.4.5 Wiring Single-Seater (BSKS600B)

Consider chapter 2.4.4 Display Illumination!

Cable loom with female connector BU1 (length 280 cm).

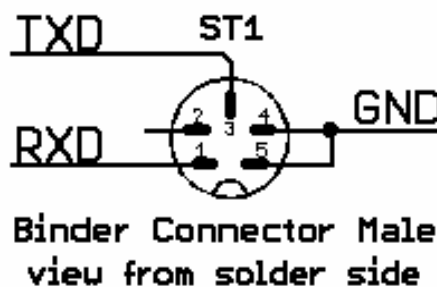
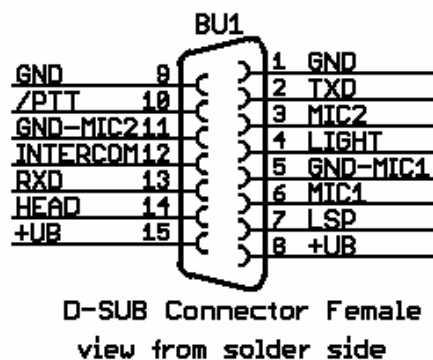
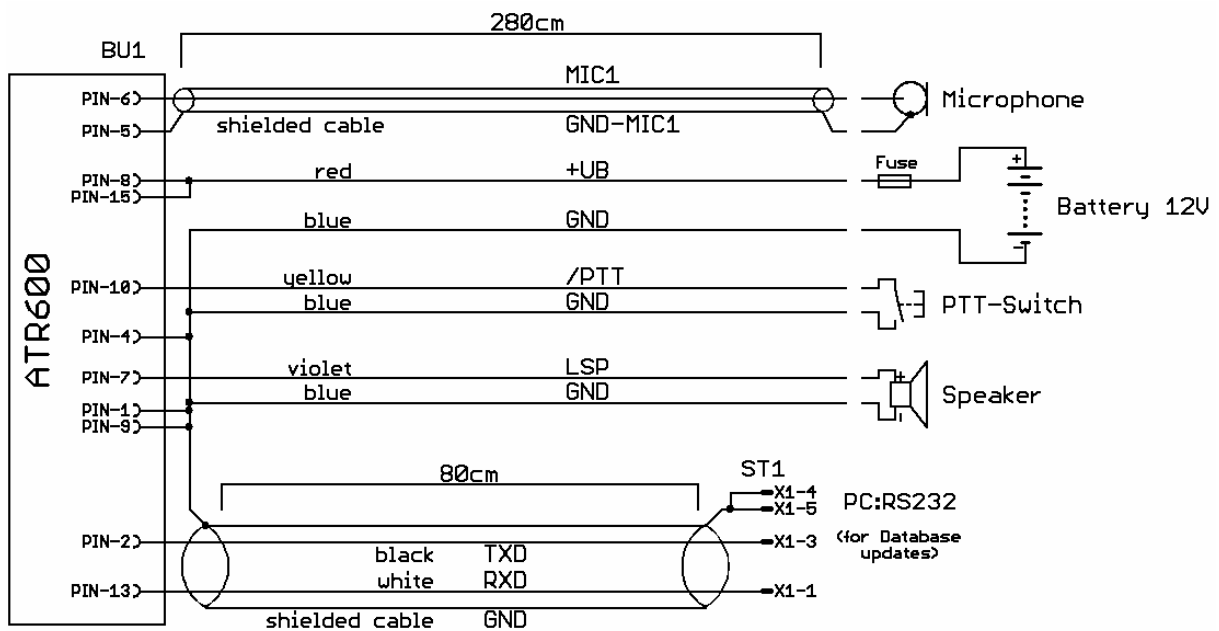

2.4.6 Wiring Double-Seater with Intercom (BSKS600S/T)

Consider chapter 2.4.4 Display Illumination!

Cable loom "BSKS600T" includes the second PTT key.

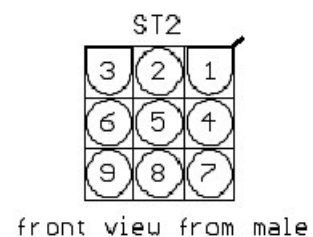
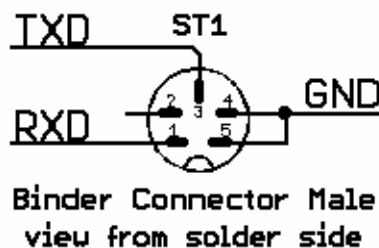
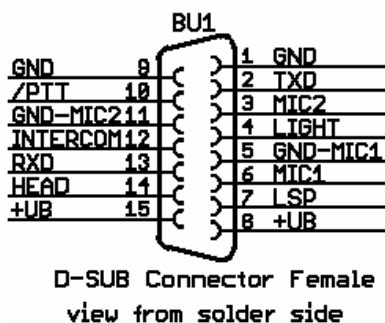
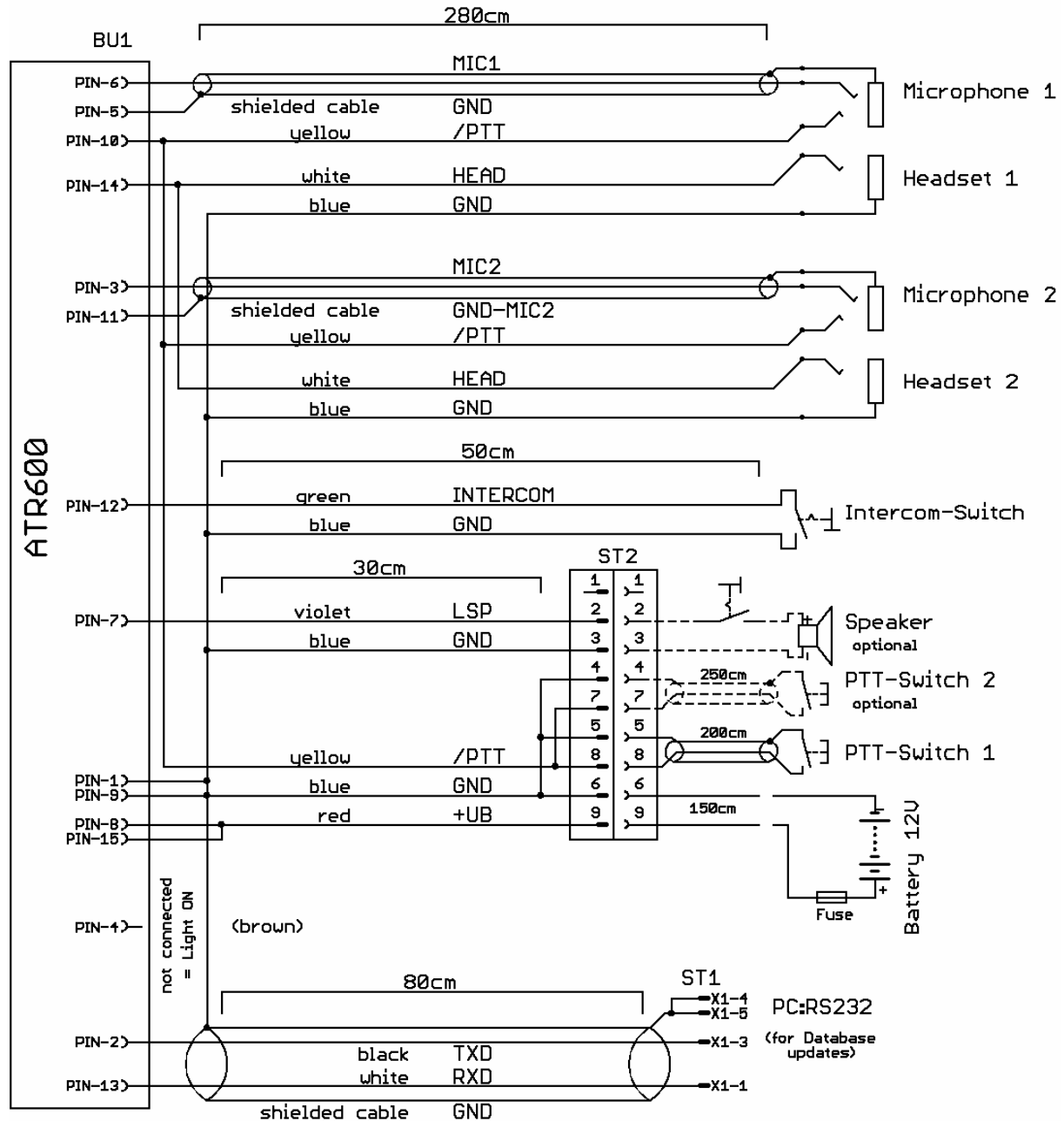

2.5 Microphone Settings

2.5.1 Basics

MIC- und VOX-values are essential for intercom.

Using VOX the loudness threshold is adjusted so that ambient noise is not transmitted to the headphones, but an additional signal caused by speaking will start intercom.

With very strong background noise or uncompensated microphones VOX can be deactivated by setting "VOX01".

In this case intercom is activated using a press-to-talk key, which connects pin 12 (intercom) of the equipment connector to GND. If necessary, e. g. in a tandem cockpit, use two parallel connected press-to-talk keys.

For operation in VOX mode pin 12 has to be connected to GND permanently.

Transmission merely operates with PTT pressed.

The suppression of background noise is only possible using differential microphones, as they are usual with modern headsets. Normal electret microphones are not suitable.



For setting refer to 4.2 INIT-Menu – Basic Settings.

2.6 Checkup after Installation

When installation is completed all steering and control functions of the aircraft are to be examined, in order to exclude disturbances by the wiring.

Subsequently, check antenna matching. Insert a standing wave meter, respectively a direction-sensitive RF power meter into the antenna line. Determine standing wave ratio (SWR) over the entire operating frequency range. The SWR shall not exceed 3:1 (the reflected power shall not exceed 25% of the forward power). If this value is exceeded, a mismatching is present, which can be caused e. g. by incorrect or insufficient electrical counterweight, bad contacting or incorrect radiator length.



With COM antennas attached on the fuselage lower side this measurement must be accomplished during flight, in order to avoid faulty measurements.

After the antenna measurement a communication test with an aeronautical station shall be accomplished.

Furthermore a test flight is recommended, in order to guarantee the proper in-flight operation of the radio:

- In a flight altitude of at least 1500 ft contact a ground station in a distance of at least 100 km (60 nautical miles).
- Pay attention to unusual electrical interference.
- If possible, perform the radio test on frequencies within the upper and lower VHF communication frequency range.

3 DRAWINGS

Equipment Dimensions

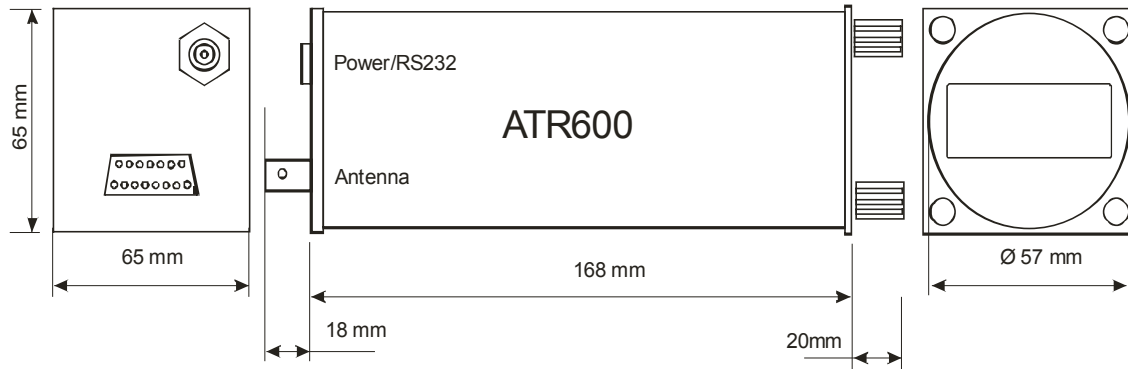

Equipment Connectors

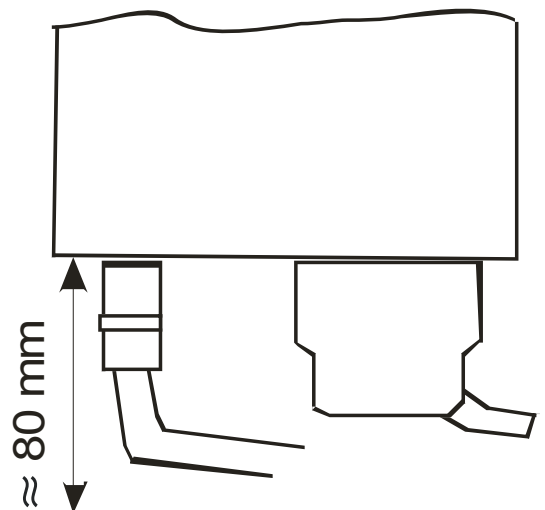

Panel Cut-out

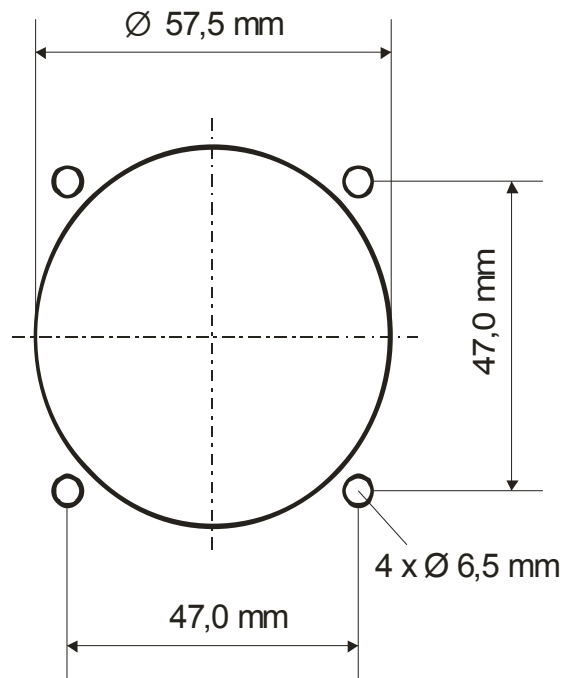

4 OPERATION

4.1 ON/OFF

- power on: press about 0.5 s
- power off: press about 3 s

Display after power on:

ATR600 VERS.1-1 DataBase 16.03.2001
--

- equipment type
- software release
- frequency database (if loaded)

4.2 INIT-Menu – Basic Settings

Enter INIT: keep SAVE pressed at power on

ERASE MIC06
D: Database
U: User Memory
No U D

Functions:

- set microphone level:
 - VOX must be set to 5 (refer to 4.3 VOL, SQ, VOX, DIM)
 - set MIC (nn = 01 .. 32): turn VOL
 The microphone level can be adjusted using headphones:
 With engine running talk loud and clearly and vary MIC until
 VOX switches on and off satisfactorily.
- erase database: press MODE
- delete user memory: press UP/DOWN
- exit: press SAVE

4.3 VOL, SQ, VOX, DIM

4.3.1 Setting Mode

After power on “VOL“ (volume) is active.

Select setting mode: press (repeatedly) SEL

The mode switches back to “VOL” after 5 s without manipulation or by selecting another frequency.



After power on the last settings are used.

4.3.2 VOL – Volume

Display: “VOLnn“, nn = 01 .. 32

Turn VOL to set headphone and speaker volume.



VOL only affects the receiver signal, not the intercom level which is set ex factory.

4.3.3 Squelch

Display: “SQnn“, nn = 01 .. 10

Turn “VOL“ to adjust the squelch threshold.

Usual settings are 03 .. 05. Superior values can cause unwanted suppression of low-level signals.



The setting of squelch does not affect the intercom function.

4.3.4 VOX – Intercom Threshold

Display: “VOXnn“, nn = 01 .. 10

Turn “VOL“ to adjust VOX to avoid transmission of ambient noise in the cockpit. Only an additional voice signal causes start of the intercom connection.

4.3.5 DIM – Background Illumination

Only P/N 600-(1XX)-(1XX)!

Display: “DIMnn“, nn = 00 .. 16

Turn “VOL“ to set intensity of the background illumination.

4.4 Transmit Function

Press PTT to start transmission on the active frequency displayed on the upper line.

After two minutes of permanent transmission is aborted.

Release and press PTT again to continue transmission.

4.5 Frequency Setting

4.5.1 General

Input options:

- direct input with the MHz/kHz controls
- select from the USER list with the MEM control
- select from the frequency database in the “DATA” Mode

Run through functions by pressing MODE.

Information of input mode (third line, right side):

- (no display): direct input or selection from USER list with MEM
- DATA: selection from database
- USER: save frequency in USER-List



Only P/N 600-(1XX)-(1XX):

Press and hold the emergency key for 5 s at any time to activate 121.5 MHz (even if the display is damaged).

4.5.2 Direct Input

Frequency can be selected with the rotary knobs MHz and kHz. It is shown as “Stand-by Frequency” in the lower line. During adjustment a present name will be overwritten (third line, left side). The appearance of the storage number changes from “[nn]” to “>nn<”, indicating that the displayed number may not comply with the displayed frequency.

CHANGE swaps previous and stand-by frequency.

4.5.3 MEM – Select from USER-List

Turn MEM to select a frequency previously stored.

Display: “[nn]“ (nn = 00 .. 99), name and frequency

Store Frequencies

The stand-by frequency shown in the lower line can be named and saved in the USER list.



Before saving, the designated memory location has to be selected with MEM in direct input mode, because when saving an existing entry will be overwritten!

Procedure:

- Turn MEM in direct input mode to select memory location.
- Select frequency directly or in data mode.
- Switch to USER mode.
- Set name with kHz and MHz (kHz places cursor, MHz selects character).
- Press SAVE to store frequency and name at the displayed memory location. For affirmation “SAVE” is shown for 2 seconds. Afterwards the equipment changes to directly input mode.

4.5.4 DATA – Select from Frequency Database

This mode is available only, if a frequency database is loaded.

- Rotary knobs MHz and kHz are used to enter the starting characters of the frequency name.
- kHz places cursor, MHz selects character
- If a suitable entry is found, name and appropriate frequency value are shown.
- At any time it is possible to select an adjacent entry with MEM.
- CHANGE swaps new stand-by and previous active frequency.
- The display changes from “[nn]“ to “>nn<”, indicating that the displayed number may not comply with the displayed frequency.
- The equipment changes to direct input mode.

4.6 Database Download

To download a database connect a PC to the RS232 port of the ATR600. The connection cable is available from Filser GmbH. Database and required software are available on www.filser.de.

Display after start of transfer software:

Start read data record #: 1234
--

Transmission status is shown by the data counter. After data transfer the device operates in normal mode.

4.7 Status and Error Messages

Display	Description
TX	normal transmitter operation
Te	Indicates transmitter auto-off after 2 minutes of permanent sending.
RX	Shown when receiving (squelch open).
BAT	Battery voltage below 10.5 V.
Er	Internal error; transmission stopped. The equipment has to be sent back to the manufacturer.



If “Er“ appears for less than 1 second, an extreme radio interference could be the reason. This is no malfunction of the device.

5 REMOTE CONTROL

In tandem cockpits operation can be performed using a remote control from the second panel.

The remote control has to be connected to the RS232 port of the ATR600.

Frequency, volume, squelch and VOX can be adjusted.

	Any malfunction of the remote control does not disturb operation of the radio!
---	--

In case of a data transfer error an error message is shown beside "VOLnn":

- 1e** = Time-out error
- 2e** = checksum error
- 3e** = unknown command

The error message disappears as soon as a correct command or a new frequency is entered.

6 CONTROLS/DISPLAY



Rotary Knobs

- 1: MEM select frequency from user list
- 2: VOL adjust volume, squelch, VOX, illumination
- 3: MHz adjust MHz
- 4: kHz select characters when assigning a name
- adjust kHz
- set cursor position when assigning a name

Push-Buttons

- 5: ON/OFF
- 6: 121.50 emergency frequency
- 7: SEL select volume, squelch, VOX, illumination
- 8: SAVE save user entries in user list
- 9: ↑ (CHANGE) swap active and stand-by frequency
- 10: MODE switch between normal operation and memory functions (USER, DATA)

Display

RX	operating mode (receive/transmit)	127.00	active frequency
CENTRE	name of active Station	VOL25	volume
MIN	name of stand-by station	(mode)	
> 2<	selected entry number in user list	118.00	stand-by frequency



